

AC

UF133(91)APA series



Size: (133 dia x 91 mm)
5.24 x 3.38 inches

- Features:** backward curved impeller
- Operating voltage (VAC):** 115 or 230
- Operating temp:** -40° ~ 50°C
- Construction:** aluminum die cast motor base
UL94V-0 reinforced nylon impeller
- Bearing option:** motor quality ball bearings
- Motor:** shaded pole
- Air flow:** centrifugal
- Connection:** 22 AWG lead wires; nom. 14 inches
- Protection:** thermal
- Insulation:** Class B

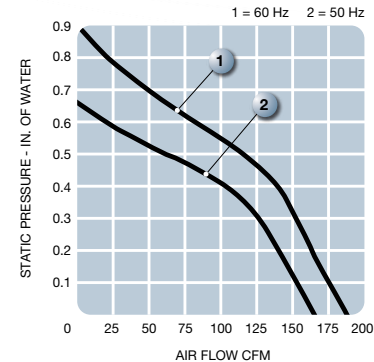
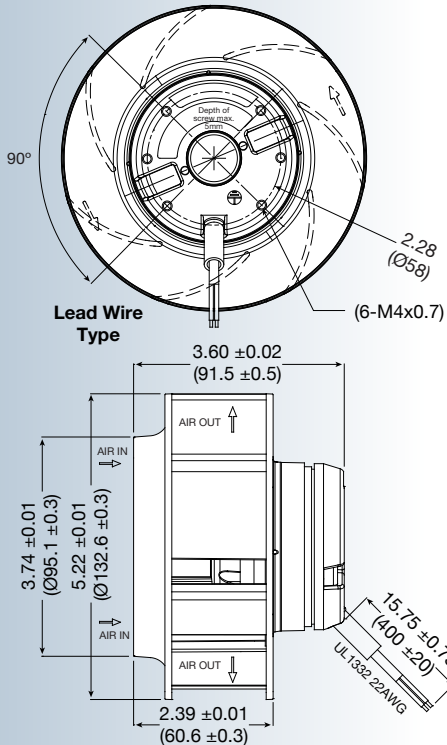

Model No.	Rated Voltage V	Freq. HZ	Input Power W	Rated Cur. A	Locked Cur. A	Speed RPM	Air Volume		Max. Static Pressure (H ₂ O)		Sound Noise dbA	Weight kg
							M ³ /Min.	CFM	MM	INCH		
UF133(91)APA12-H1S2A	115	50	38	0.50	0.83	2780	4.66	165	16.6	0.65	50	0.9
	115	60	37	0.43	0.72	3200	5.33	188	22.4	0.88	60	0.9
UF133(91)APA23-H1S2A	230	50	36	0.24	0.39	2780	4.66	165	16.6	0.65	50	0.9
	230	60	35	0.21	0.34	3200	5.33	188	22.4	0.88	60	0.9