

UF15KCR series

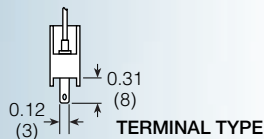
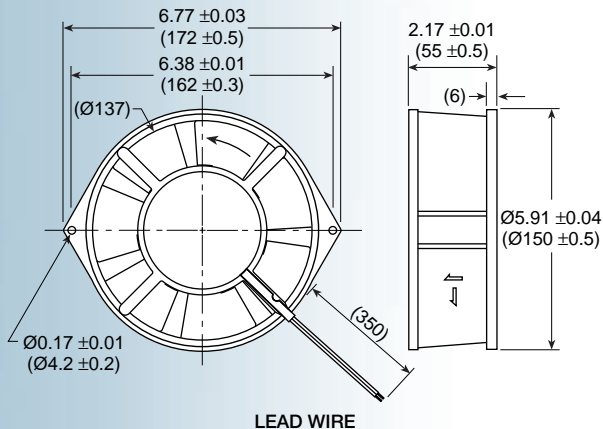

Size: (172 x 150 x 55 mm)
6.77 x 5.91 x 2.17 inches

Features: *capacitor start motor;*
reverse air flow (air intake over
struts); Class B insulation

Operating voltage (VAC): 115 or 230

Construction: aluminum die cast frame;
 UL94V-0 PBT impeller

Bearing option: motor quality ball bearings

Motor: capacitor start

Air flow: intake over struts

Connection: terminal or 22 AWG lead wire

Protection: thermal

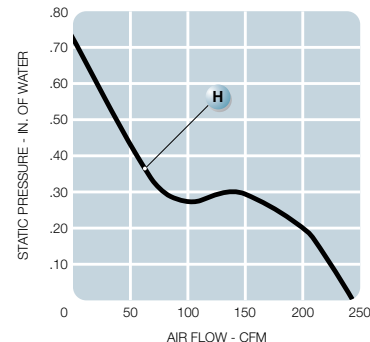

Model No.	Rated Voltage V	Freq. HZ	Input Power W	Rated Cur. A	Locked Cur. A	Speed RPM	Air Volume		Max Static Pressure (H ₂ O)		Sound Noise dB	Wt OZ
							M ³ /Min	CFM	MM	INCH		
UF15KCR12-__H	115	60	30	0.25	0.58	3,400	6.8	241	18.5	0.73	66	38
UF15KCR23-__H	230	60	31	0.13	0.28	3,400	6.8	241	18.5	0.73	66	38