

## UF15KMR series

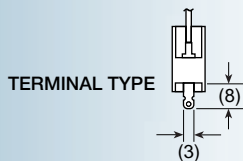
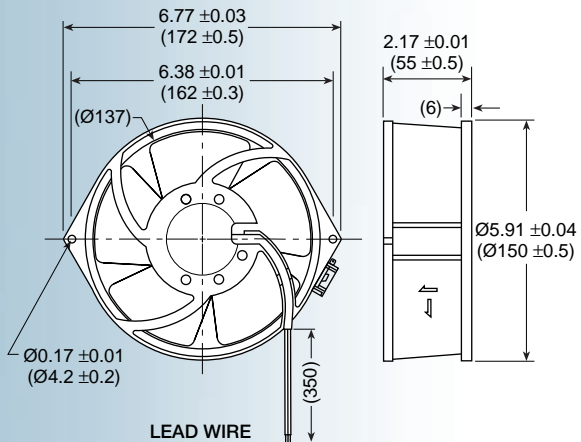

**Size: (172 x 150 x 55 mm)**  
**6.77 x 5.91 x 2.17 inches**

**Features:** *metal frame and impeller;*  
*Class F (155°) insulation;*  
*-40°C ~ 90°C operating*  
*temperature range;*  
*high-temp bearing lubricant*

**Operating voltage (VAC):** 115 or 230

**Construction:** aluminum die cast frame;  
 metal impeller

**Bearing option:** motor quality ball bearings

**Motor:** shaded pole

**Air flow:** intake over struts

**Connection:** terminal or 22 AWG lead wire

**Protection:** thermal

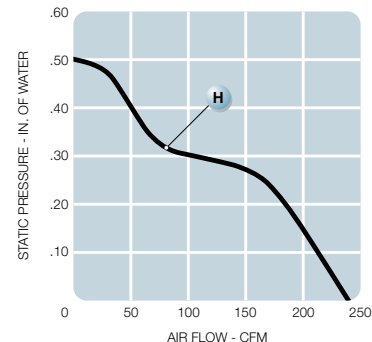

Model No.	Rated Voltage V	Freq. HZ	Input Power W	Rated Cur. A	Locked Cur. A	Speed RPM	Air Volume		Max Static Pressure (H <sub>2</sub> O)		Sound Noise dB	Wt OZ
							M <sup>3</sup> /Min	CFM	MM	INCH		
UF15KMR12-__H	115	60	45	0.51	0.80	3,150	7.2	255	12.5	0.50	61	39
UF15KMR23-__H	230	60	45	0.25	0.38	3,150	7.2	255	12.5	0.50	61	39