

G8015-G series

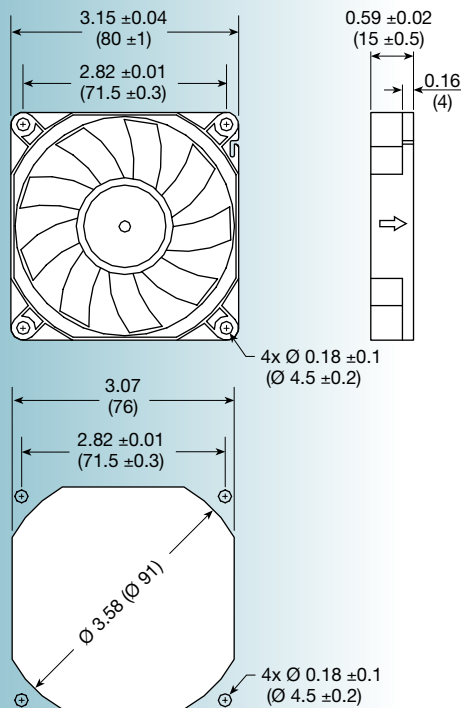

Size: (80 x 80 x 15 mm)
3.15 x 3.15 x 0.59 inches

Features: *high pressure impeller design*

Construction: UL94V-0 PBT impeller & frame

Bearing option: ball bearing or sleeve

Connection: AWG 26, UL1007 lead wires

Frame: ribbed

Protection: thermal

Options: tachometer output or locked rotor alarm signal; encapsulated motor

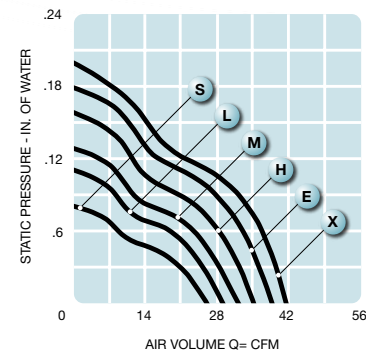

Model No.	Rated Voltage V	Current mA			Revolution RPM	Air Volume		Max. Static Pressure (H ₂ O)		Sound Noise dbA	Weight oz
		5	12	24		M ³ /Min.	CFM	MM	INCH		
G8015S-G	5/12/24	200	100	80	2,800	0.73	26	2.14	0.08	29	2.25
G8015L-G	5/12/24	280	130	90	3,200	0.82	29	2.74	0.11	32	2.25
G8015M-G	5/12/24	380	180	120	3,600	0.92	32	3.36	0.13	34	2.25
G8015H-G	12/24	-	230	150	4,000	0.99	35	3.97	0.16	36	2.25
G8015E-G	12/24	-	320	180	4,400	1.11	39	4.69	0.18	38	2.25
G8015X-G	12/24	-	350	250	4,800	1.20	42	5.12	0.20	40	2.25